

# DEFIANT<sup>®</sup>

## INSECT SCREENS



DEFIANT

# DEFIANT

All Defiant Insect screens are carefully built to exacting standards, giving years of trouble-free service. The superior design features and quality components enable them to be confidently specified for the most demanding environments.

The provision of insect screens at door and window openings is a legal requirement in areas where food is prepared for public consumption, such as restaurants, works canteens, schools, hospitals and all public buildings. Defiant screens comply with the relevant Health and Safety regulations, and all frame sections are manufactured from hygienic white powder-coated aluminium extrusions. The PVC-coated glass fibre mesh is rot-proof and flame-retardant.

The greatly enhanced interior environment provided by Defiant screens is an important contributor to the quality of life in many situations, both residential and commercial. The screens are unobtrusive, with simple and attractive detailing and quality components.

Defiant insect screens are available through a nationwide network of distributors, with experienced installation and service teams providing an unrivalled level of support.

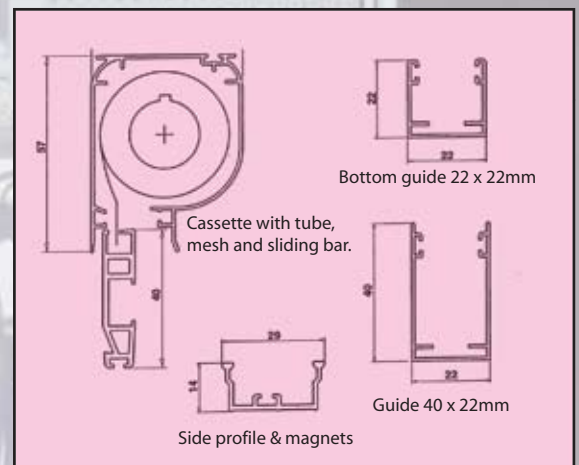

## Defiant Insect screens- size limitations

| Screen | Min width | Max width | Min drop | Max drop | Max m <sup>2</sup> |
|--------|-----------|-----------|----------|----------|--------------------|
| F30    | 800       | 1600      | 400      | 2500     | 3.5                |
| F32    | 600       | 1800      | 400      | 2500     | 3.5                |
| F40    | 400       | 1200      | 1000     | 2500     | 3.0                |
| F40D   | 800       | 2500      | 1000     | 2500     | 6.0                |

## Maintenance

All Defiant insect screens are designed to require low maintenance. The components and mechanisms are made from durable materials and will not corrode in normal use. In the event of damage to components, spare parts are available from the manufacturers or their distributors.

# Insect Screens

## F30 Roll-up chain operation



- Retractable screen with simple bead-chain sidewinder control
- Discreet and attractive cassette and guide channel profiles
- Suitable for almost all types of window or door opening
- Cassette and guide channels in white powder-coated extruded aluminium - other colours to order
- Quality mechanism and high-grade nylon fittings ensure trouble-free operation
- PVC-coated fibreglass mesh is rot-proof and flame-retardant

**Specification:** Defiant F30 Insect screen as supplied by Better Blind Company, 0161 367 9013. Roll-up screen with white aluminium cassette, guide channels and bottom bar. Sidewinder operation with plastic control chain and rot-proof, flame retardant PVC-coated fibreglass mesh.

## F32 Roll-up spring operation



- Retractable screen with advanced slow-rise spring operation
- Wide range of commercial and domestic applications
- Slim and attractive profiles will complement any decor
- Cassette and guide channels in white powder-coated extruded aluminium - other colours to order.
- Quality mechanism and high-grade nylon fittings ensure trouble-free operation
- PVC-coated fibreglass mesh is rot-proof and flame-retardant

**Specification:** Defiant F32 Insect screen as supplied by the Better Blind Company, 0161 367 9013. Roll-up screen with white aluminium cassette, guide channels and bottom bar. Spring operation with decelerator mechanism and rot-proof, flame-retardant PVC-coated fibreglass mesh.

## F40 / F40D Roll-across door units



- Horizontally retracting single (F40) or double (F40D) screens with smooth spring operation
- Suitable for doorways or large window openings
- Slim and unobtrusive 41mm cassette to one side (F40) or both sides (F40D) of doorway
- Cassette and guide channels in white powder-coated extruded aluminium - other colours to order.
- PVC coated fibreglass mesh is rot proof and flame retardant
- Designed for reliability, with quality components and reliable mechanisms

**Specification:** Defiant F40/F40D Insect screen as supplied by the Better Blind Company. Horizontally retracting single/double screen with white aluminium cassette(s) and guide channels. Spring operation, with rot-proof, flame retardant PVC coated fibreglass mesh.

## Better Blind Company

Newblinds House, Wych Fold, SK14 5ED

Tel: 0161 367 9013 Fax: 0161 367 9318

Email: [enquiries@thebetterblindcompany.co.uk](mailto:enquiries@thebetterblindcompany.co.uk)